

# Soft Seated

Isolator Ball Valves

## TYPE KHL 510

- 1/2" - 6", ANSI Class 150-300
- Flange & face-to-face-dimensions:  
ASME B 16.5, 16.10
- Materials:  
CF8M 316 SS  
A216 WCB
- Temperature range:  
-58°F to +392°F

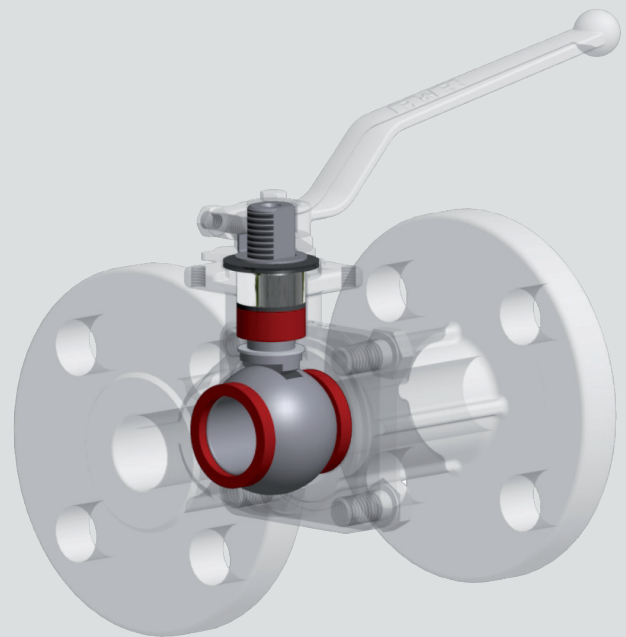

# TYPE KHL 510

## Dimensional Drawing

flange connection according to ASME B16.5

flange facing: standard raised face (others on request)

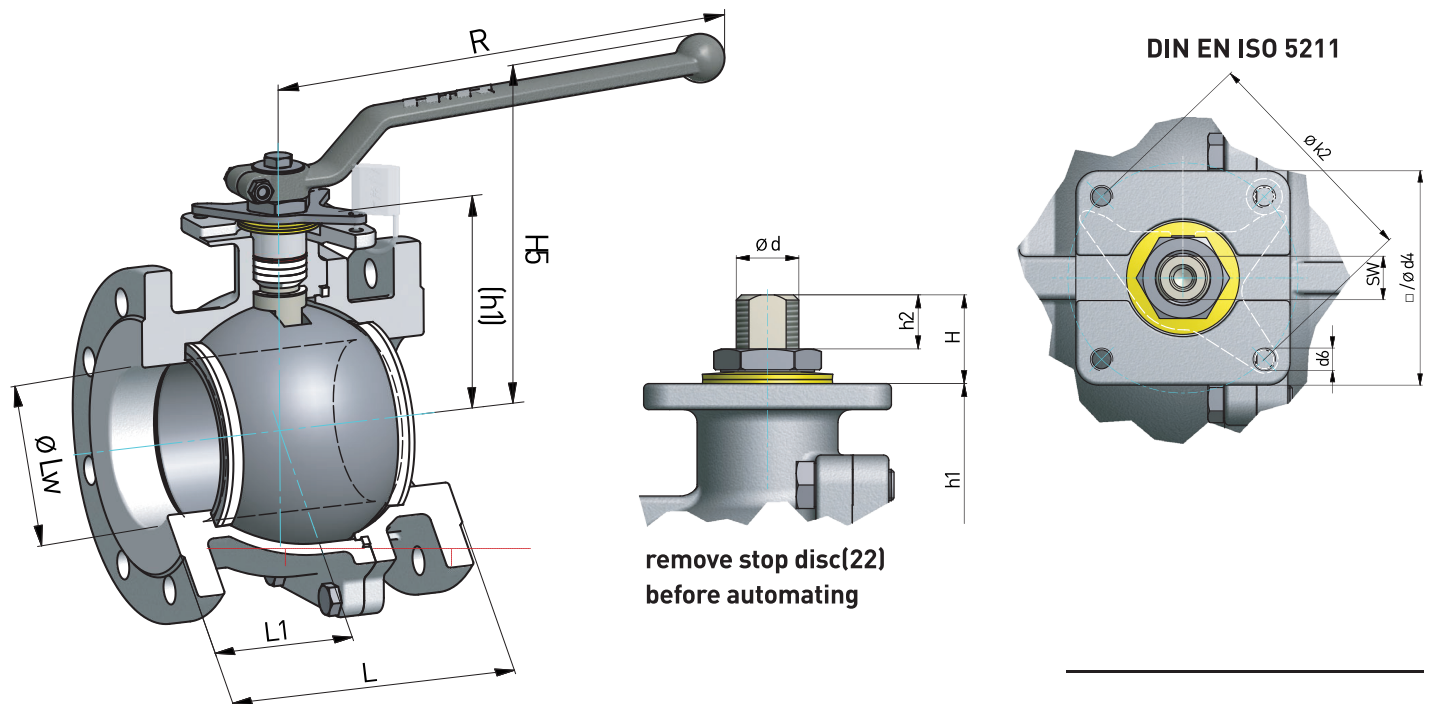

ISO 5211	øk2	d6	ø/□d4
F 05	1.97	4 x M6	□ 1.77
F 07	2.76	4 x M8	□ 2.56
F 10	4.02	4 x M10	□ 3.74
F 12	4.92	4 x M12	ø5.96

## MEASURING GUIDE TYPE KHL 510

NPS	Lw	L	L1	H	h1	h2	ød	SW	H5	R	Weight Lbs		ISO 5211			
											150	300				
1/2"	in	0.63	4.25	5.50	1.89	1.89	0.81	2.17	0.43	M16 x 1,5	0.49	4.76	6.10	5.1	6.4	F05
3/4"	in	0.79	4.62	6.00	1.89	1.89	0.81	2.17	0.43	M16 x 1,5	0.49	4.76	6.10	5.7	8.6	F05
1"	in	0.98	5.00	6.50	1.89	2.48	0.81	2.17	0.43	M16 x 1,5	0.49	4.76	6.10	6.4	9.9	F05
1 1/2"	in	1.50	6.50	7.50	2.66	2.66	1.14	2.87	0.43	M20 x 1,5	0.55	5.67	9.06	14.8	20.1	F07
2"	in	1.97	7.00	8.50	2.66	3.17	1.14	3.19	0.67	M20 x 1,5	0.55	6.02	9.06	20.3	26.5	F07
2 1/2"	in	2.56	7.50	9.50	3.05	3.05	1.14	3.82	0.67	M20 x 1,5	0.55	6.57	9.06	28.4	40.8	F07
3"	in	3.00	8.00	11.12	3.25	3.64	1.34	4.53	0.79	M24 x 2	0.76	7.28	11.81	44.8	60.4	F10
4"	in	3.94	9.00	12.00	3.64	4.04	1.34	5.20	0.79	M24 x 2	0.76	7.95	11.81	67.0	92.4	F10
6"	in	5.91	15.50	15.88	6.89	7.68	2.24	8.44	2.24	M44 x 1,5	1.26	10.91	31.50	208.3	252.4	F12

# TYPE KHL 510

Exploded View

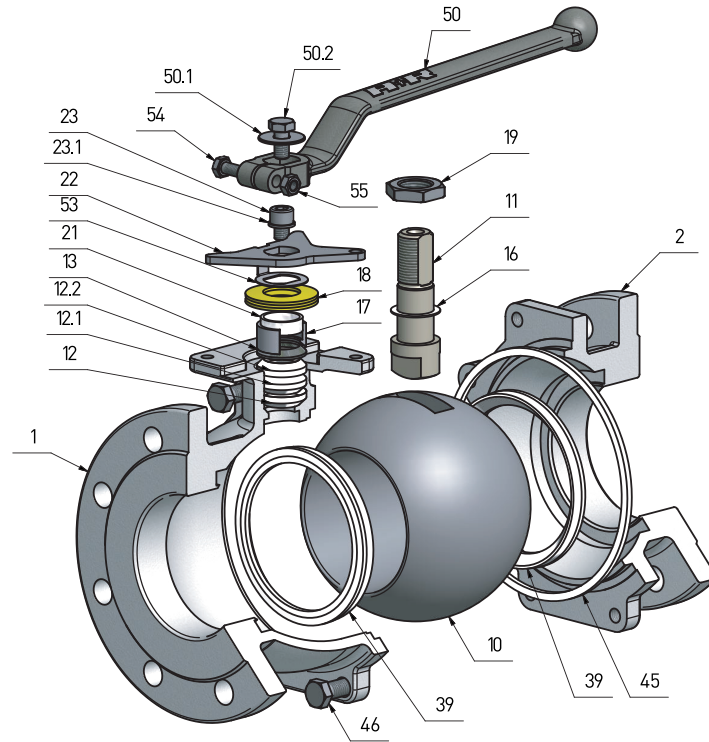

## BILL OF MATERIALS TYPE KHL 510

Item No.	Item	stainless steel version	carbon steel version
1	Body	CF8M 316 SS	A216 WCB
2	Side cap	CF8M 316 SS	A216 WCB
10	Ball	CF8M 316 SS	CF8 304 SS
11	Stem	316 SS	316 SS
12	Stem seal <sup>1</sup>	PTFE	PTFE
12.1	Stem seal <sup>1</sup>	PTFE	PTFE
12.2	Stem seal <sup>1</sup>	PTFE	Graphite
13	Anti-static ring <sup>1</sup>	PTFE+Carbon	-
16	Thrust ring <sup>1</sup>	RPTFE	RPTFE
17	Ring	303 SS	303 SS
18	Cup spring	301 SS	301 SS
19	Nut	304 SS	304 SS
21	Slide bushing <sup>1</sup>	RPTFE	RPTFE
22	Stop disc	304 SS	304 SS
23	Hex.-socket screw	304 SS	304 SS
23.1	Spring washer	304 SS	304 SS
39	Ball seat <sup>1</sup>	RPTFE	RPTFE
45	Body seal <sup>1</sup>	PTFE	Graphite
46	Hex bolt	316 SS	304 SS
50	Handle	304 SS	304 SS
50.1	Washer	304 SS	304 SS
50.2	Hex bolt	304 SS	304 SS
53	Lock washer	304 SS	304 SS
54	Hex bolt	304 SS	304 SS
55	Nut	304 SS	304 SS

<sup>1</sup> recommended spare parts

# TYPE KHL 510

Accessories

## manual worm gear type AR

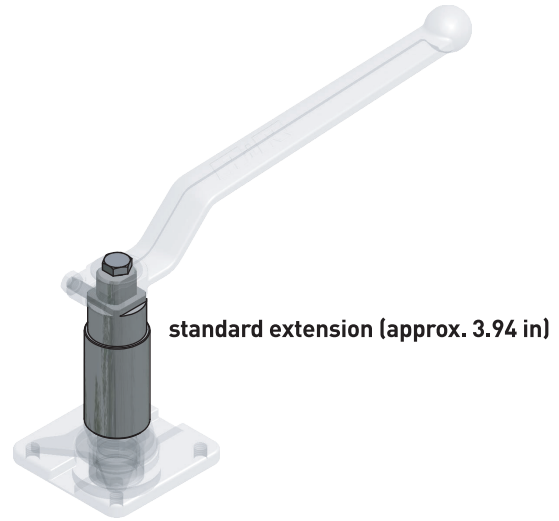
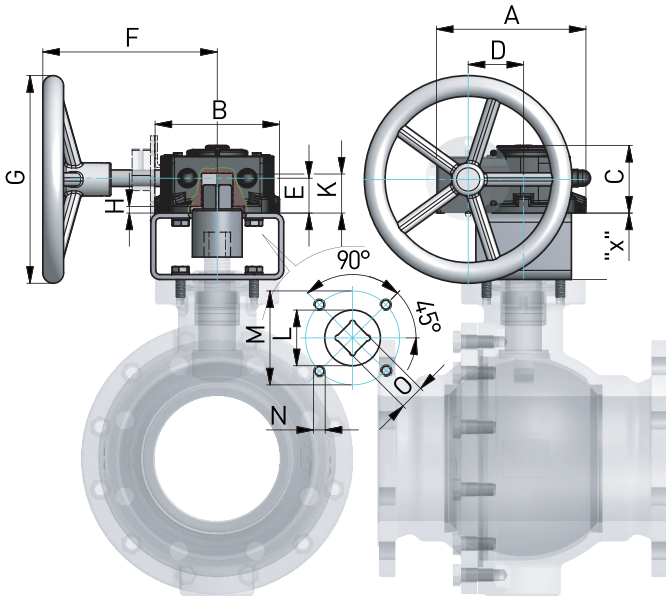

### MANUAL WORM GEAR

TYPE AR

Type	max. torque	A	B	C	D	E	F	G	H	K	L	M	N	O	ISO 5211
AR 1	1,770 in-lb	4.45	3.31	2.52	1.71	1.12	6.04	6.30	0.18	1.18	1.38	2.76	M8	0.67	F07
AR 2	7,080 in-lb	7.28	5.31	3.56	2.71	1.67	10.53	9.84	0.10	1.97	2.36	4.92	M12	1.06	F12
AR 2,5	13,275 in-lb	8.11	6.14	3.82	3.31	1.77	12.91	19.69	0.08	2.36	3.35	5.51	M16	1.42	F14
AR 3	17,700 in-lb	9.29	7.09	3.94	3.80	1.97	13.39	19.69	0.08	2.56	3.35	5.51	M16	1.42	F14

### DIMENSION OF BRACKET "x"

STANDARD

gear box	ball valve		
	ISO 5211	F 10	F 12
AR 1	F 07	3.15	3.15
AR 2	F 12	3.15	3.15
AR 2,5	F 14	-	3.15
AR 3	F 14	-	3.15

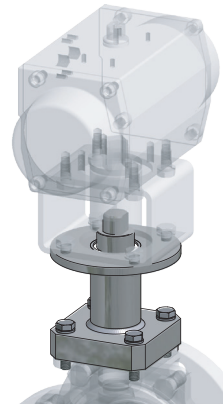

ISO - flange - support tube

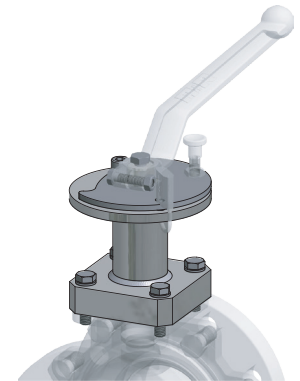

locking, blocking device

### DESIGN FEATURES:

- PED 2014/68/EU, AD-2000
- ASME B16.5, B16.10, B16.34
- TA-Luft
- Fire-Safe
- Leakagerate „A“ EN 12266-1/ Class VI FCI 70-2

**A+R Valve USA, LLC**

**PO Box 1514 // Statesboro, GA 30459-1514 // PH (912) 489-1377**

**bbunting@ar-armaturen.com // bryce@AR-US.com // www.AR-US.com**

**A+R - Armaturen® GmbH**

Altenhagener Str. 4a // 32107 Bad Salzfluten // Tel. +49 5208 - 9102 - 0 // Fax. +49 5208 - 9102 - 90

Email: postoffice@ar-armaturen.com // Web: www.ar-armaturen.com

© A+R Rev. 01 / 03.18 de-en

technische Änderungen vorbehalten / technical changes reserved