

## Metal Seated

High Performance Ball Valves

### TYPE KHF 710

- 1/2" - 12", ANSI Class 150-600
- Flange & face-to-face-dimensions:  
ASME B 16.5, B 16.10
- Materials:  
CF8M  
WCB  
Special Materials (Duplex,  
Hastelloy C4...etc.) on request
- Temperature range:  
-58°F up to +752°F, up to 1200°F on request

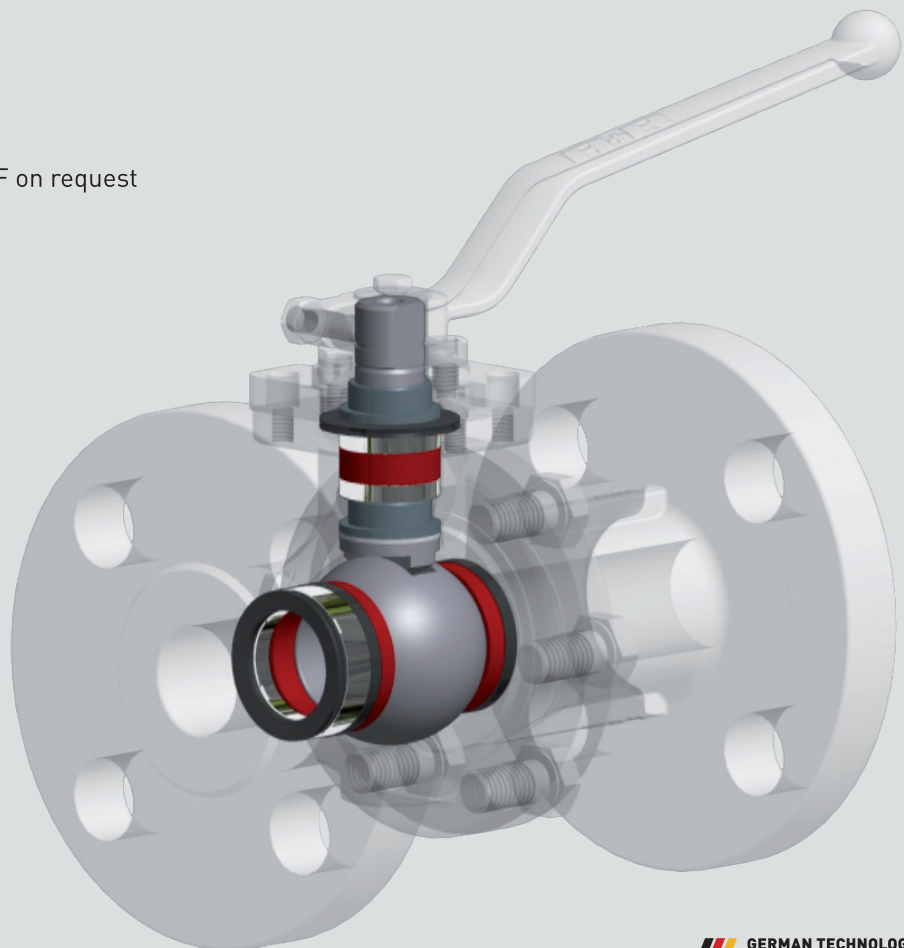

# TYPE KHF 710 metal seats

## Dimensional Drawing

flange connection according to ASME B16.5

flange facing: standard raised face (others on request)

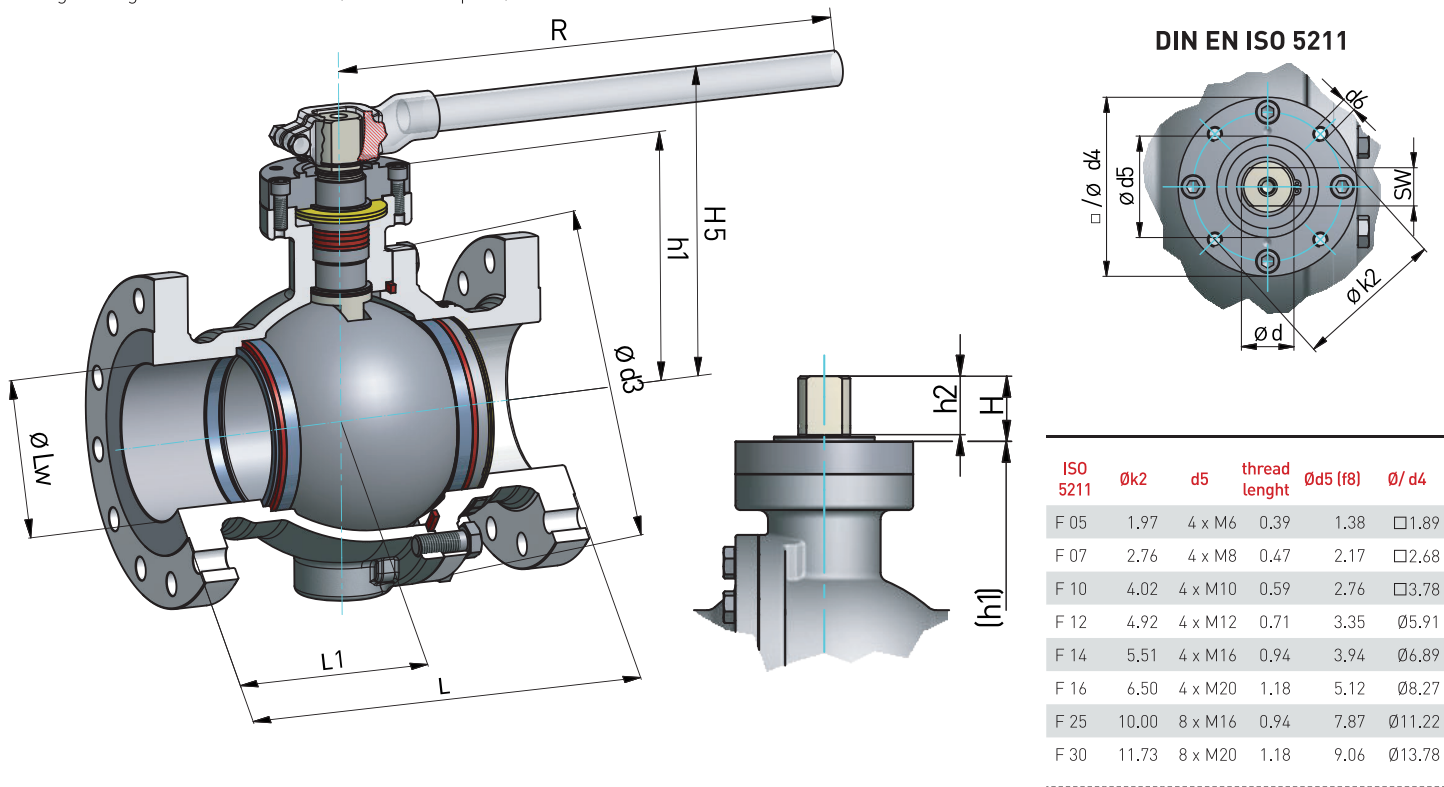

## MEASURING GUIDE TYPE KHF 710 metal seats

NPS	Lw	L			L1			H		h1		h2		Ød		SW		Ød3			H5			R			Weight Lbs			ISO 5211		
		150	300	600	150	300	600	150	300	600	150	300	600	150	300	600	150	300	600	150	300	600	150	300	600	150	300	600	150	300	600	
1/2" in	0.63	4.25	5.50	6.50	1.85	1.85	2.28	0.67	0.67	2.48	2.48	0.39	0.39	0.63	0.63	0.49	0.49	3.54	3.54	3.58	5.24	6.30	6.6	8.1	9.2	F05	F05	F05				
3/4" in	0.75	4.62	6.00	7.50	1.89	1.89	2.28	0.67	0.67	2.48	2.48	0.39	0.39	0.63	0.63	0.49	0.49	3.54	3.54	3.58	5.24	6.30	7.2	10.3	100	F05	F05	F05				
1" in	0.98	5.00	6.50	8.50	1.89	2.48	3.07	0.67	0.67	2.48	2.48	0.39	0.39	0.63	0.63	0.49	0.49	3.54	3.54	4.13	5.24	6.30	8.1	11.6	15.6	F05	F05	F05				
1 1/2" in	1.50	6.50	7.50	9.50	2.66	2.66	4.04	1.14	1.14	3.15	3.15	0.55	0.55	0.79	0.79	0.55	0.55	4.72	4.72	5.12	6.22	8.46	16.13	23.3	29.7	F07	F07	F07				
2" in	1.97	7.00	8.50	11.50	2.76	3.05	4.43	1.30	1.30	3.66	3.66	0.71	0.71	0.79	0.79	0.55	0.55	5.98	6.10	6.30	6.73	8.46	26.6	33.9	43.6	F07	F07	F07				
2 1/2" in	2.52	7.50	9.50	13.00	3.15	3.15	4.04	1.38	1.38	4.53	4.53	0.71	0.71	0.79	0.79	0.55	0.55	7.48	7.48	7.48	7.68	8.46	42.9	50.7	65.4	F10	F10	F10				
3" in	3.00	8.00	11.12	14.00	3.25	4.04	5.61	1.46	1.46	4.90	4.90	0.79	0.79	0.98	0.98	0.76	0.76	7.95	7.95	8.46	8.31	11.81	54	71.4	91.9	F10	F10	F10				
4" in	3.94	9.00	12.00	17.00	3.72	4.63	6.40	1.46	1.46	5.55	5.55	0.79	0.79	0.98	0.98	0.76	0.76	9.25	9.37	9.96	8.98	11.81	79.5	107.3	166.4	F10	F10	F10				
6" in	5.91	15.50	15.88	22.00	6.89	7.68	8.27	2.17	2.17	9.55	9.55	1.63	1.63	1.73	1.73	1.26	1.26	12.60	12.60	14.37	11.85	31.50	209.8	250.8	401.2	F12	F12	F12				
8" in	7.87	18.00	19.75	26.00	8.27	9.25	10.43	2.17	2.17	11.02	11.02	1.63	1.63	1.73	1.73	1.26	1.26	15.63	15.94	18.31	13.31	31.50	351.6	426.1	768.3	F12	F12	F16				
10" in	9.84	21.00	22.38	31.00	9.65	10.83	12.20	2.36	3.19	12.99	13.27	2.01	2.91	1.89	2.76	1.42	1.97	19.17	19.88	21.26	-	-	563.2	726.6	1313.9	F14	F16	F25				
12" in	11.81	24.00	25.50	33.00	10.63	12.01	14.17	2.36	4.72	14.37	18.11	2.01	3.92	1.89	3.86	1.42	2.95	22.44	22.83	25.20	-	-	797.6	1007.2	2039.1	F14	F16	F30				

# TYPE KHF 710 metal seats

Exploded View I & II

**Fig. I:**  
Floating  
ball,  
live load  
NPS 1/2" - 12"

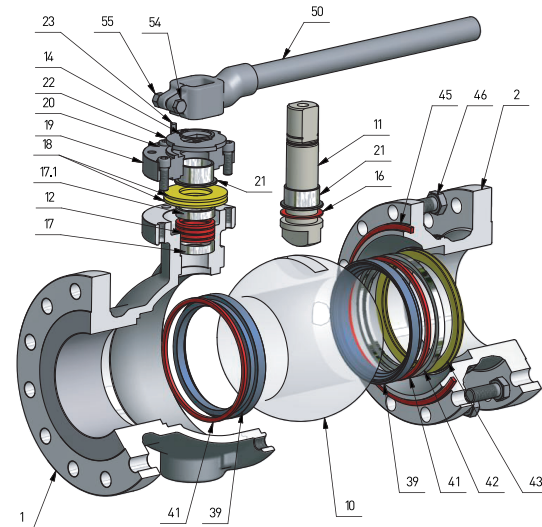

**Fig. II:**  
Trunnion  
mounted  
ball,  
live load  
NPS 3" - 12"

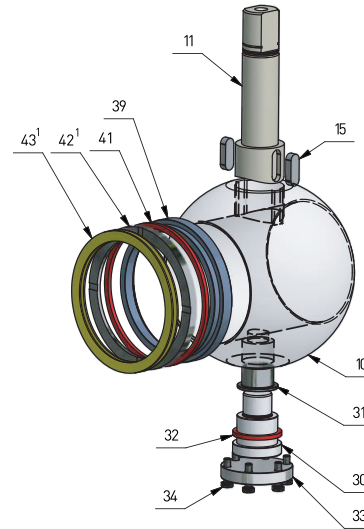

## BILL OF MATERIALS TYPE KHF 710 metal seats

Positions Nr. / Item No.	Item	stainless steel version	carbon steel version
1	Body	CF8M	WCB
2	Side cap	CF8M	WCB
10	Ball <sup>2,3</sup>	CF8M	CF8M
11	Stem	318 LN	318 LN
12	Stem seal <sup>2</sup>	Graphite	Graphite
14	Safety ring	301	301
15	Key <sup>1</sup>	316 Ti	316 Ti
16	Thrust ring <sup>2</sup>	Graphite	Graphite
17	Ring	316L	316L
17.1	Ring	316L	316L
18	Cup spring	301	301
19	Cover	CF8M	CF8M
20	Hex.-socket screw	304	304
21	Bearing bush <sup>3</sup>	316 SS	316 SS
22	Stop disc	304	304
23	Limit stop	304	304
30	Trunnion <sup>1</sup>	316L	316L
31	Bearing bush <sup>1,3</sup>	316L	316L
32	Trunnion seal <sup>1,2</sup>	Graphite	Graphite
33	Cover <sup>1</sup>	316L	carbon steel
34	Hex bolt <sup>1</sup>	316	304
39	Ball seat <sup>2,3</sup>	316 Ti	316Ti
41	Seat ring <sup>2</sup>	Graphite	Graphite
42	Ring	316L	316L
43	Cup spring	Inconel	Inconel
45	Body gasket <sup>2</sup>	Graphite	Graphite
46	Hex bolt	316	304
50	Handle	CF8	CF8
54	Hex bolt	steel galvanized	steel galvanized
55	Nut	steel galvanized	steel galvanized

<sup>1</sup> Only for trunnion mounted design

<sup>2</sup> Recommended spare parts

<sup>3</sup> Coating Options: Boride, Tungsten carbide, Chrome carbide

# TYPE KHF 710 metal seats

Accessories

## manual worm gear type AR

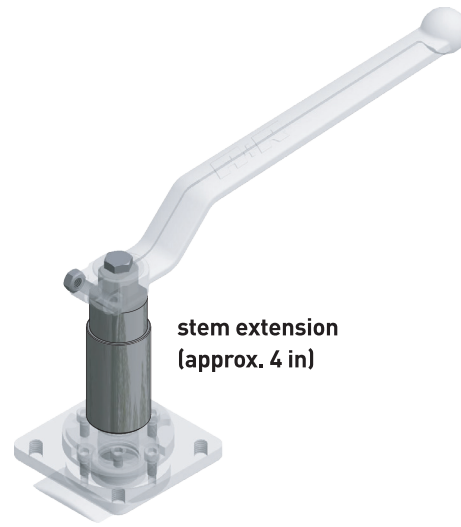
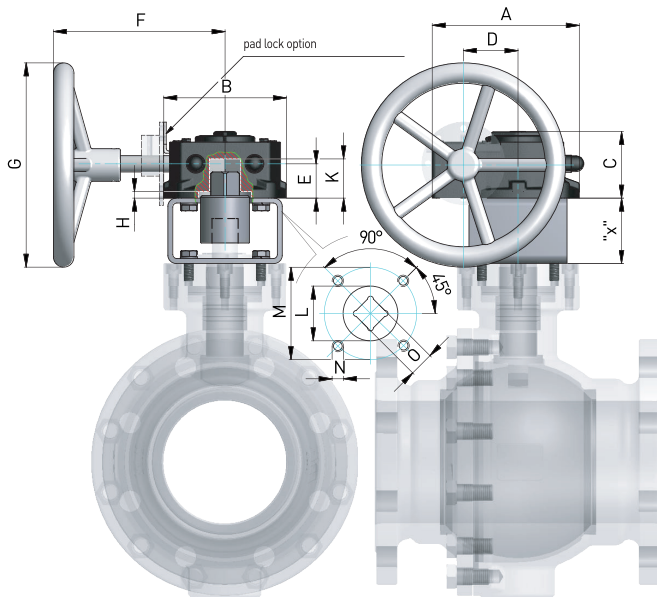

### MANUAL WORM GEAR

TYPE AR

Type	max. Torque	A	B	C	D	E	F	G	H	K	L	M	N	O	ISO 5211
AR 1	1,770 in-lb	4.45	3.31	2.52	1.71	1.12	6.04	6.30	0.18	1.18	1.38	2.76	M8	0.67	F07
AR 2	7,080 in-lb	7.28	5.31	3.56	2.71	1.67	10.53	9.84	0.10	1.97	2.36	4.92	M12	1.06	F12
AR 2,5	13,275 in-lb	8.11	6.14	3.82	3.31	1.77	12.91	19.69	0.08	2.36	3.35	5.51	M16	1.42	F14
AR 3	17,700 in-lb	9.29	7.09	3.94	3.80	1.97	13.39	19.69	0.08	2.56	3.35	5.51	M16	1.42	F14
AR 3,5	26,550 in-lb	10.98	9.84	4.63	4.63	1.91	14.96	23.62	0.08	2.95	4.53	6.50	M20	1.81	F16
AR 4	35,400 in-lb	12.83	11.10	5.04	5.41	2.15	16.69	23.62	0.14	2.95	5.12	6.50	M20	1.81	F16
AR 5	57,525 in-lb	13.39	11.10	5.04	5.41	2.15	17.95	23.62	0.14	2.95	5.12	10.00	M16	2.17	F25

### DIMENSION OF BRACKET "x"

STANDARD

gear box	ball valve						
	ISO 5211	F 10	F 12	F 14	F 16	F 25	F30
AR 1	F 07	3.15	3.15	-	-	-	-
AR 2	F 12	3.15	3.15	3.15	-	-	-
AR 2,5	F 14	-	3.15	3.15	-	-	-
AR 3	F 14	-	3.15	3.15	3.94	-	-
AR 3,5	F 14	-	3.15	3.15	3.94	7.87	-
AR 4	F 16	-	3.94	3.94	3.94	7.87	-
AR 5	F 25	-	-	7.87	7.87	7.87	7.87

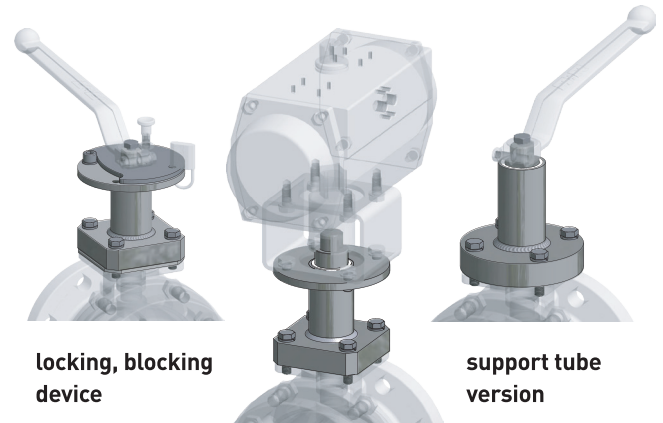

### DESIGN FEATURES:

- PED 2014/68/EU, AD-2000
- ASME B16.34
- TA-Luft
- Fire-Safe
- Zero leakage/ Class VI FCI 70-2
- Live load state of the art sealing system
- Floating or trunnion mounted ball

## A+R Valve USA, LLC

PO Box 1514 // Statesboro, GA 30459-1514 // PH (912) 489-1377

bbunting@ar-armaturen.com // bryce@AR-US.com // www.AR-US.com

## A+R - Armaturen® GmbH

Altenhagener Str. 4a // 32107 Bad Salzfluten // Tel. +49 5208 - 9102 - 0 // Fax. +49 5208 - 9102 - 90

Email: postoffice@ar-armaturen.com // Web: www.ar-armaturen.com

© A+R Rev. 01 / 03.18 de-en

technische Änderungen vorbehalten / technical changes reserved